

# Dorris. GEAR DRIVES

## Base Mounted Gear Drive Installation, Lubrication and Maintenance Instructions

### Assembly of Backstop

When an optional backstop is to be used with the gear drive, it must be specified when the gear drive is ordered. See Figure 1.

The backstop housing (6) has been installed at the factory, but the backstop (8) is shipped loose. Remove the backstop housing (6), shim gasket (3) and flat cap (10) from gear drive housing (5) by removing bolts (11). If the backstop housing (6) contains two snap rings, remove the snap ring (7) only. Take care not to damage shim gasket (3) or cap gasket (9).

**NOTE: All backstop housings contain one snap ring that is located on the side adjacent to the gear drive housing (5). This is installed at the factory.**

**CAUTION: Note direction of rotation indicated by the arrow on the backstop to allow shaft rotation in that direction.**

Install the backstop (8), key (not shown), and the snap ring (7) (if previously removed) into the backstop housing (6). Place the previously removed shim gasket(s) (3) on the face of the gear drive housing (5). If the shim gasket (3) or cap gasket (9) has been damaged, contact factory to obtain the necessary new shim gaskets and assembly instructions.

Slide the assembled housing (6) onto the backstop shaft extension. While sliding the backstop housing onto the backstop shaft extension, rotate the backstop housing opposite the direction of the arrow, to allow for ease of installation. Do NOT use excessive force. Bolt the installed housing (6), shim gasket (3), cap gasket (9) and flat cap (10) with bolts (11) treated with a locking adhesive to the gear drive housing (5).

Turn the input shaft by hand to ensure that it locks in the desired direction and rotates freely in the opposite direction without excessive end play. Torque bolts (11) to 25 ft-lbs.

**WARNING: Never use an EP additive oil with a backstop because the enhanced lubrication properties of EP oils may cause the backstop to slip.**

**WARNING: Backstops may not be used for people moving. Backstops have a maximum overrun speed of 1800 rpm. Indexing, ratcheting or jogging is not permitted.**

**WARNING: Failure to comply with these instructions or disassembly of the gear drive will void the gear drive warranty.**

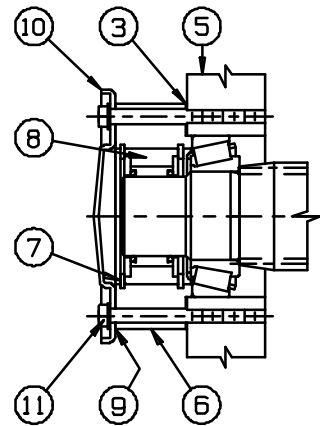

Figure 1 - Backstop Assembly

### Installation

Be sure that the base supporting the gear drive and motor is solid and that the anchor bolts are securely fastened to a good foundation.

If the gear drive is to be direct coupled on the input shaft by a flexible coupling, leave at least a 1/8 inch gap between the motor shaft and the gear drive input shaft. Also, align the gear drive input shaft and the motor output shaft as closely as possible to help ensure efficient coupling performance.

Before mounting couplings, sheaves or sprockets on the shaft extensions of the gear drive, apply a thin coat of anti-seize compound or lithium based grease to the shafts. This will make removing them easier should that be necessary. Mount these items as close as possible to the gear drive housing in order to keep overhung loads to a minimum. The limits on overhung loads, based on the model number, are listed in Table 1. This table assumes that the overhung load is located at the midpoint of the keyway on the shaft or closer to the gear drive housing. Consult The Dorris Company if you have any questions concerning overhung loads.

Brake adaptors are available for some brakes. Consult The Dorris Company if a brake adaptor is desired.

**Install the proper guards or other safety devices as specified in all applicable safety codes and regulations. Guards and other safety devices are neither supplied by nor are they the responsibility of The Dorris Company.**

## Assembly of Optional Motor Mount to Gear Drive

There are two different type of motor mounts for the base mounted gear drives. The motor mounts for the 900, 9900 and 10000 series bolt to the face of the gear drive, while the motor mounts for the 1200-9500 series bolt to the top of the unit by replacing the cover plate.

For a motor mount on the 900, 9900 and 10000 series, bolt the two support brackets to the housing with the four bolts that are provided. For the 900 series only, the legs of the brackets should be turned away from the input shaft extension. Bolt the base plate to the brackets using the four nuts, bolts and lock washers that are provided.

For a motor mount on the 1200-9500 series remove the cover plate and gasket on the top of the gear drive. Install the new gasket that is provided. Then mount the base plate to the top of the gear drive with the special length bolts also provided.

Assemble the four jack screws to the base plate with one nut on the bottom and one nut on the top side of the base plate.

After threading one more nut on each jack screw, assemble the motor support plate to the four jack screws, with the holes in the motor support plate forming an arrowhead pointing toward the input shaft extension. The remaining nuts are then threaded on to the jack screws.

Ensure that all nuts and bolts are securely attached and properly torqued.

## Assembly of Motor and V-Belt to Optional Motor Mount

Match motor mounting holes with holes in the motor plate. When properly matched the motor shaft will be aligned with the input shaft. Securely attach the motor to the plate using the proper type and grade of fastener.

**CAUTION: Do not assemble the V-Belt drive to the motor until it has been wired and checked for the proper direction of rotation.**

Ensure that the electrical service to the motor is disconnected and locked out prior to proceeding with the installation.

When the gear drive is equipped with a backstop, check shafts for the proper direction of rotation.

Install the V-Belts. **AVOID EXCESSIVE TENSIONING.** V-Belts must have a slight bow on the slack side when operating. The overhung load limits for the input shaft are given in Table 1.

After V-Belts are properly adjusted by the jack screws on the motor mount, tighten the jack screw nuts.

**Table 1 - Overhung Load Capacities at Midpoint of Keyway**

| UNIT SERIES | MODELS      | OVERHUNG LOAD LIMITS (LBS) |              |
|-------------|-------------|----------------------------|--------------|
|             |             | INPUT SHAFT                | OUTPUT SHAFT |
| 900         | 9068-9059   | 400                        | 1000         |
|             | 9056-9052   | 450                        | 1000         |
|             | 9049-9047   | 325                        | 1000         |
|             | 9044-9040   | 200                        | 1000         |
|             | 9036-9028   | 150                        | 1000         |
|             | 9024-9015   | 75                         | 500          |
| 1200        | 1236-1205   | 250                        | 1250         |
| 1800        | 1820-1815   | 350                        | 1800         |
|             | 1814-18105  | 250                        | 1800         |
|             | 1809-18065  | 100                        | 1550         |
| 2800        | 2841-2833   | 430                        | 3100         |
|             | 2829-2/24   | 600                        | 3100         |
|             | 2821-2815   | 700                        | 3100         |
|             | 2814-2811   | 550                        | 2500         |
|             | 2810-2807   | 475                        | 2200         |
| 3800        | 3841-3834   | 620                        | 4630         |
|             | 3831-3823   | 525                        | 4630         |
|             | 3821-3817   | 450                        | 4630         |
|             | 3816-3813   | 300                        | 4270         |
|             | 3811-38074  | 100                        | 3600         |
| 5800        | 5840-5829   | 650                        | 6300         |
|             | 5826-5822   | 900                        | 6000         |
|             | 5815        | 1875                       | 5450         |
|             | 5809        | 1875                       | 4650         |
| 8300        | 8340-8329   | 690                        | 6430         |
|             | 8324        | 930                        | 6430         |
|             | 8318-8315   | 1120                       | 6430         |
|             | 8310-8309   | 2000                       | 6430         |
| 8500        | 8540-8529   | 690                        | 6430         |
|             | 8524        | 930                        | 6430         |
|             | 8520-8513   | 2000                       | 6430         |
| 9100        | 9184-9170   | 2250                       | 15500        |
|             | 9160-9148   | 2225                       | 14000        |
|             | 9145-9136   | 2200                       | 12000        |
|             | 9126-9120   | 2200                       | 11000        |
| 9300        | 93133-93100 | 2200                       | 16000        |
|             | 9380-9370   | 2150                       | 14000        |
|             | 9359-9340   | 2100                       | 11000        |
|             | 9337-9330   | 2000                       | 9500         |
|             | 9327-9323   | 2000                       | 8200         |
| 9500        | 95133-95100 | 2150                       | 14000        |
|             | 9580-9570   | 2100                       | 12000        |
|             | 9559-9550   | 2000                       | 11000        |
|             | 9540-9537   | 1950                       | 9000         |
|             | 9533-9530   | 1850                       | 8000         |
|             | 9527-9523   | 1750                       | 6900         |
| 9900        | 99250-9960  | 2500                       | 20000        |
|             | 9940        | 1200                       | 20000        |
|             | 9925        | 1100                       | 20000        |
|             | 9915        | 1100                       | 18000        |
| 10000       | 10200-10060 | 2000                       | 20000        |
|             | 10040       | 2500                       | 20000        |
|             | 10025       | 2500                       | 20000        |
|             | 10015       | 2200                       | 18000        |

## Lubrication

**CAUTION: All Dorris gear drives are shipped without oil. Do not assume that this unit has been properly lubricated. Prior to start-up, be sure that the proper type, grade and amount of oil has been installed into the gear drive.**

Lubricate the gear drive by filling the unit to the proper level, per these instructions. Select the proper type and grade of oil based on the ambient air temperature range around the gear drive. Choose an oil that meets the requirements of Table 2. Table 3 lists some oil brand names that meet the requirements in Table 2. Other oil companies may have equivalent oils to those listed.

Make sure that the coolest ambient temperature is at least 10°F greater than the pour point of the oil chosen.

Industrial petroleum-based rust and oxidation inhibited (R&O) gear oils are recommended for most applications. Automotive motor oils are not recommended.

Extreme pressure (EP) additive oils are not recommended and are never to be used if the gear drive has an optional backstop installed.

Synthetic, hydrocarbon-type (polyalphaolefin base) gear oils without EP additives are recommended for ambient temperatures as low as -20°F or as high as 170°F. However, consult Dorris for proper oil selection for applications where the ambient temperature is greater than 100°F.

When the gear drive is used in the food processing industry, ensure that the lubrication is approved for the application.

The oil capacity of the unit is dependent on its mounting position. See Figure 2 and Table 4. The oil capacities are based upon the mounting position shown, and assume an output speed of the gear drive being 10 rpm or more. For speeds less than 10 rpm, or other arrangements not shown, consult the Dorris Company.

**Table 2 - Oil Selection**

| AMBIENT TEMP RANGE (°F) | R & O (RUST & OXIDATION INHIBITED) GEAR OIL FOR UNITS WITH OR WITHOUT A BACKSTOP |                    | VISCOSITY RANGE                         |             |
|-------------------------|--|--------------------|---|-------------|
|                         | AGMA R & O LUBE NUMBER   | ISO VG R & O GRADE | cSt (mm <sup>2</sup> /s) @ 40°C (104°F) | SUS @ 100°F |
| 15 - 75                 | 3  | 100                | 90 - 110                                | 417 - 510   |
| 32 - 100                | 4  | 150                | 135 - 165                               | 626 - 765   |
| 50 - 125                | 5  | 220                | 198 - 242                               | 918 - 1122  |

**Table 3 - Selective Oil Brand Names**

### R & O Gear Oils

| COMPANY  | ISO VISCOSITY GRADE     |                         |                               |
|----------|-------------------------|-------------------------|-------------------------------|
|          | 100 (AGMA 3)            | 150 (AGMA 4)            | 220 (AGMA 5)                  |
| AMOCO    | American Ind'l Oil 100  | American Ind'l Oil 150  | American Ind'l Oil 220        |
| CHEVRON  | Machine Oil R&O ISO 100 | Machine Oil R&O ISO 150 | RPM Gear Oil SAE 90 (ISO 220) |
| CITGO    | Pacemaker Oil 100       | Pacemaker Oil 150       | Pacemaker Oil 220             |
| CONOCO   | Dectol R&O Oil 100      | Dectol R&O Oil 150      | Dectol R&O Oil 220            |
| EXXON    | Teresstic 100           | Teresstic 150           | Teresstic 220                 |
| MOBIL    | DTE Heavy               | DTE Extra Heavy         | DTE BB                        |
| PHILLIPS | Magnus Oil ISO VG 100   | Magnus Oil ISO VG 150   | Magnus Oil ISO VG 220         |
| SHELL    | Morlina Oil 100         | Morlina Oil 150         | Morlina Oil 220               |
| SUN      | Sunvis 9100             | Sunvis 9150             | Sunvis 9220                   |
| TEXACO   | Regal Oil R&O 100       | Regal Oil R&O 150       | Regal Oil R&O 220             |

### Synthetic Hydrocarbon Type Gear Oils

| COMPANY | LOW TEMP (0° TO 60°F) * | NORMAL TEMP (50° TO 125°F) | HIGH TEMP (100° TO 170°F) |
|---------|-------------------------|----------------------------|---------------------------|
| MOBIL   | SHC 626                 | SHC 630                    | Consult Factory           |
| TEXACO  | Pinnacle 68             | Pinnacle 220               | Consult Factory           |
| AMSOIL  | RCJ 68                  | RCM 220                    | Consult Factory           |

\* -20°F possible if no backstop installed.

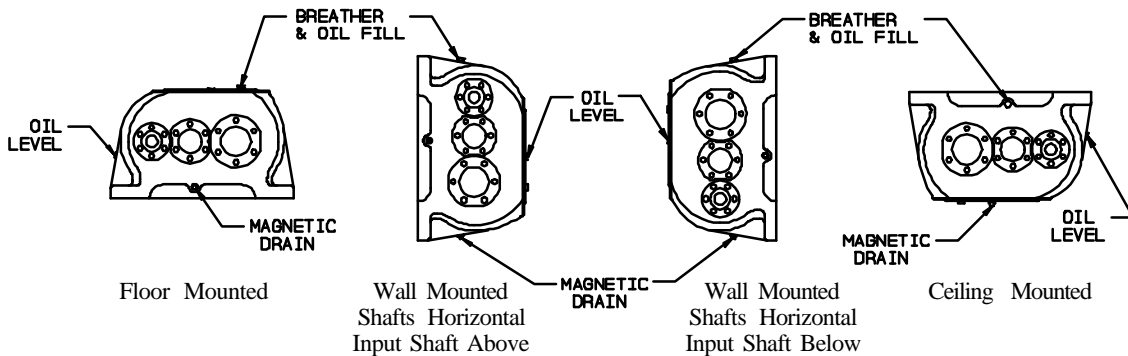

**Figure 2 - Gear Drive Orientations**

**Maintenance**

Change the oil after an initial period of 500 hours of operation or one month, whichever occurs first.

Thereafter, for a petroleum-based gear oil, change the oil every 2500 hours of operation or every six months, whichever occurs first. If a synthetic, hydrocarbon-type gear oil is used, the recommended oil change interval is doubled to 5000 hours or 12 months, whichever occurs first.

In cases of severe service applications, such as extreme exposure to water, high humidity, dirty or dusty environment or chemicals in the air, which react with lubrication oil, the oil change interval must be shortened depending on the severity of the conditions.

For better drainage, drain the oil when the unit is warm. Remove and examine the magnetic drain plug for metal chips and fines. An excessive amount of metal fines signals internal problems. Consult the Dorris Company if you think the amount is excessive. Small amounts of metal fines are normal and should simply be cleaned off prior to reinstallation. After draining, thoroughly flush the inside of the unit with clean oil. Remove and clean the breather plug to ensure that the air passage is clear. Reinstall the drain plug and breather plug after using a thread sealant.

For units that see a significant seasonal swing in ambient temperature, you should change the grade of oil as needed (lighter oil in the winter, heavier oil in the summer).

Do not allow the gear drive to become covered with dirt, dust or other debris. The insulating properties of these coverings could cause the unit to overheat. This will lead to a breakdown of the lubrication, causing premature failure of the gear drive components.

In environments where a buildup of unwanted surface coverings is expected, clean the outer surfaces of the gear drive often. Ensure that the breather is clear after cleaning.

Check the unit for oil leakage and the source of that leakage. The most common leak points are pipe plugs and oil seals. Operation of the unit when full of oil causes overheating and leakage through the oil seals and the breather plug. Rather than waiting for parts during unscheduled down time, you may wish to order replacement parts when the leaks are minor. Occasionally, the breather plug is not properly located

at the highest point on the unit. Relocate the breather plug, if required, especially if the lubricant is foaming out of the breather. Many leaks are caused by overfilling the unit with oil. Check for the proper level. Do not let any leak go unattended as the loss of oil will eventually cause a failure.

**Storage**

If the unit is not going to be operated for an extended period of time (greater than two months), you have two options. Either fill the unit completely with the proper oil for long term storage or fill it to the operating level and run it for a minimum of half an hour per week to coat the internal parts with oil. Either procedure will help prevent internal oxidation of the critical parts. Before resuming use, ensure that the oil is of the proper type and at the proper level. Operation of the unit when full of oil causes overheating and leakage through the oil seals and the breather plug.

Store the gear drive in a dry location where the temperature remains relatively constant, not passing through the dew point. Do not store the unit outdoors. If the temperature passes through the dew point, moisture will condense on the inside of the unit, reducing the life of the gear drive.

**Table 4 - Oil Capacity**

| UNIT SERIES | APPROXIMATE CAPACITY IN QUARTS |                        |                        |               |
|-------------|--------------------------------|------------------------|------------------------|---------------|
|             | FLOOR MOUNT                    | WALL MOUNT INPUT ABOVE | WALL MOUNT INPUT BELOW | CEILING MOUNT |
| 900         | 2                              | 3                      | 3                      | 2             |
| 1200        | 2                              | 1 1/2                  | 1 1/2                  | 2             |
| 1800        | 3                              | 4                      | 5                      | 3             |
| 2800        | 5                              | 7                      | 5                      | 7             |
| 3800        | 7                              | 7                      | 7                      | 7             |
| 5800        | 12                             | 16                     | 12                     | 12            |
| 8300        | 13                             | 16                     | 14                     | 10            |
| 8500        | 13                             | 16                     | 32                     | 17            |
| 9100        | 22                             | 40*                    | 32                     | 17            |
| 9300        | 22                             | 40*                    | 32                     | 17            |
| 9500        | 22                             | 40*                    | 32                     | 17            |
| 9900        | 37                             | 80*                    | 70                     | 37            |
| 10000       | 37                             | 80*                    | 70                     | 37            |

\*Oil level increased. Lube Pump no longer necessary.

**Dorris Company, Inc.**

8610 Page Avenue, St. Louis, MO 63114-6183  
 Phone 314.423.7300 ~ Fax 314.423.8083  
 info@dorrisco.com